

YANG IRON PRECISION CORP.

Tax ID number : 28579018

- YANG IRON factory
No. 38-2, Lianwu Rd., Dali District.,
Taichung City 41277, Taiwan
TEL : 886-4-2492-5886
FAX : 886-4-2492-5887
- YOUNG TAI factory
No. 45, Section 3, Changlong Road,
Taiping Dist., Taichung City 41101, Taiwan
TEL : 886-4-2276-5588
FAX : 886-4-2276-5599



CENTERLESS GRINDER

www.yungtai.com

Precision Manufacture / Perfect Design / Excellent Quality / Profession Service

Centerless Grinder

YTC-12

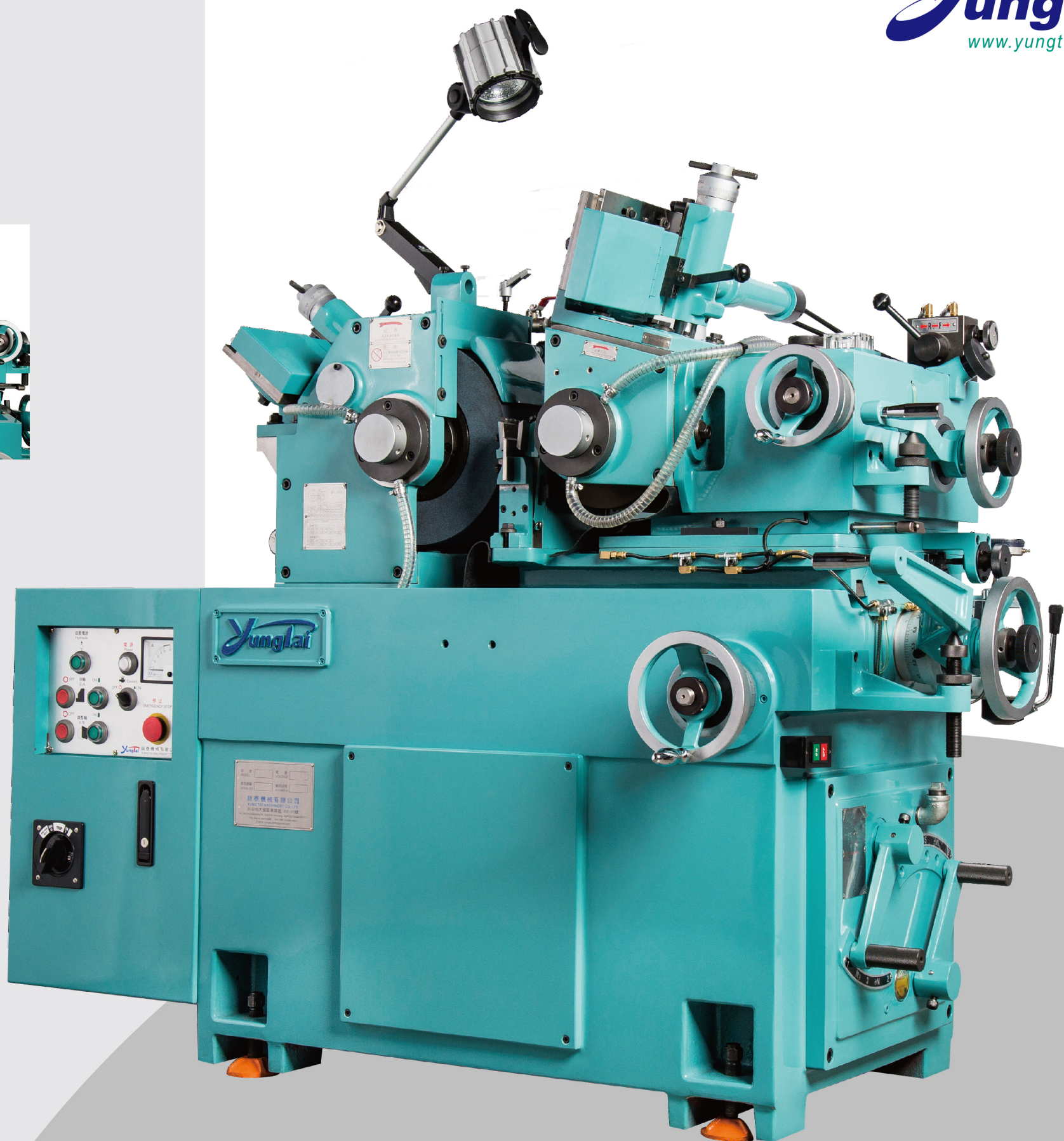
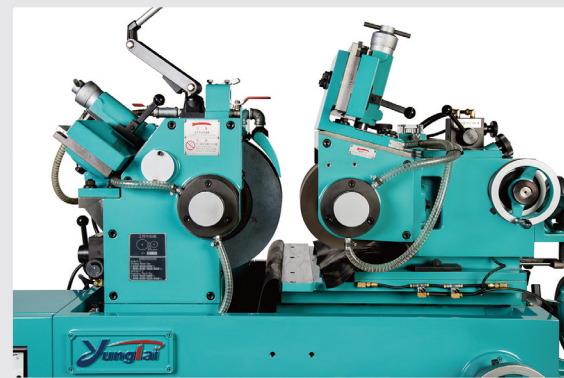
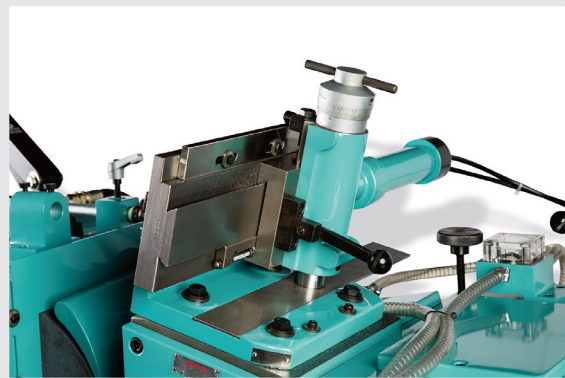

SPECIFICATION

Model No.	YTC-12
Standard grinding range (Dia.)	Ø1~Ø30mm
Capacity increases with special arrangement	Ø30~Ø60mm
Grinding wheel size (OD x Width x ID)	Ø305 x 150 x Ø120mm
Regulating wheel speed	1950 R.P.M.
Grinding wheel motor	7.5 HP
Regulating wheel size (OD x Width x ID)	Ø205 x 150 x Ø90mm
Regulating wheel speed	20~337 R.P.M. (10 Steps)
Regulating wheel motor	1 HP
Regulating wheel tilt angle	+5° ~ -3°
Regulating wheel swivel angle	±5°
Upper slide feed graduation	3.5mm/rev ; 0.05mm/graduation
Upper slide micro-feed graduation	0.1mm/rev ; 0.001mm/graduation
Lower slide feed graduation	7mm/rev ; 0.05mm/graduation
Lower slid micro-feed graduation	0.2mm/rev ; 0.001mm/graduation
Trimming device graduation	1.25mm/rev ; 0.01mm/graduation
Hydraulic pump motor	1 HP
Coolant pump motor	1/8 HP
Machine dimension (L x W x H)	1650 x 1550 x 1350mm
New weight / Gross weight	1650 kg / 1850 kg

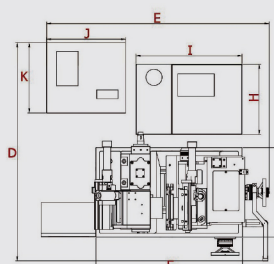
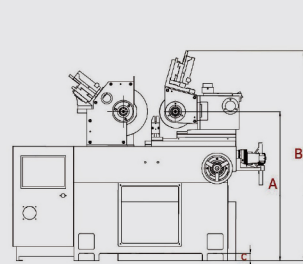

A	B	C	D	E	F
940	1350	45	1550	1650	1025

G	H	I	J	K
625	490	740	550	490

(mm)

※We reserve the right to change the design and specifications of our products without further notice.

Servo type Centerless Grinder

YTC-12S

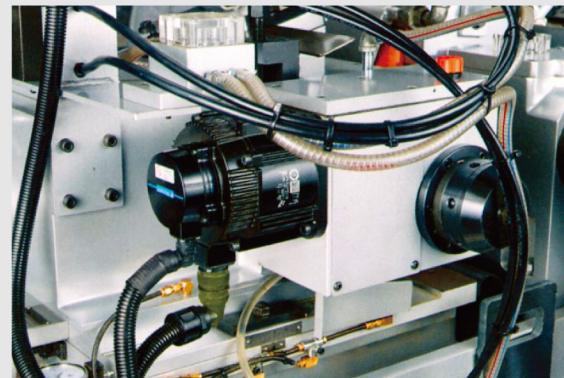

Regulating wheel servo motor:
(Servo type Centerless Grinder)
Japan made Servo motor supply 10~300R.P.M. continuously variable transmission to drive the worms and gears in order to reduce the grinding vibration and achieve the best grinding.

SPECIFICATION

Model No.	YTC-12S
Standard grinding range (Dia.)	Ø1~Ø30mm
Capacity increases with special arrangement	Ø30~Ø60mm
Grinding wheel size (OD x Width x ID)	Ø305 x 150 x Ø120mm
Regulating wheel speed	1950 R.P.M.
Grinding wheel motor	7.5 HP
Regulating wheel size (OD x Width x ID)	Ø205 x 150 x Ø90mm
Regulating wheel speed	10~300 R.P.M. (Stepless)
Regulating wheel motor	1.3 KW Servo motor
Regulating wheel tilt angle	+5° ~ -3°
Regulating wheel swivel angle	±5°
Upper slide feed graduation	3.5mm/rev ; 0.05mm/graduation
Upper slide micro-feed graduation	0.1mm/rev ; 0.001mm/graduation
Lower slide feed graduation	7mm/rev ; 0.05mm/graduation
Lower slid micro-feed graduation	0.2mm/rev ; 0.001mm/graduation
Trimming device graduation	1.25mm/rev ; 0.01mm/graduation
Hydraulic pump motor	1 HP
Coolant pump motor	1/8 HP
Machine dimension (L x W x H)	1650 x 1550 x 1350mm
New weight / Gross weight	1600 kg / 1800 kg

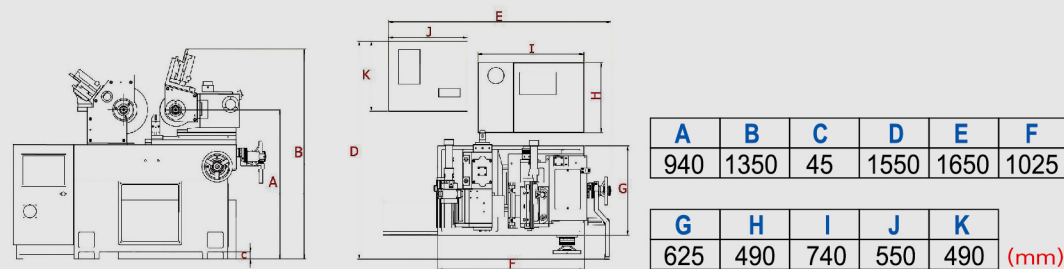

※We reserve the right to change the design and specifications of our products without further notice.

Centerless Grinder YTC-18

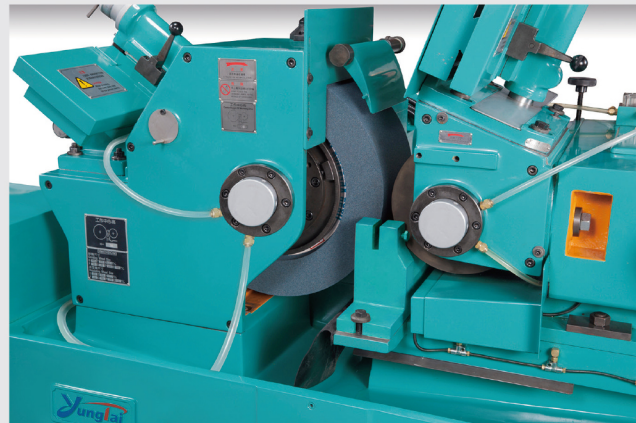

SPECIFICATION

Model No.	YTC-18
Standard grinding range (Dia.)	Ø2~Ø60mm
Capacity increases with special arrangement	Ø50~Ø150mm
Grinding wheel size (OD x Width x ID)	Ø455 x 205 x Ø228.6mm
Regulating wheel speed	1380 R.P.M.
Grinding wheel motor	15 HP
Regulating wheel size (OD x Width x ID)	Ø255 x 205 x Ø111.2mm
Regulating wheel speed	13~316 R.P.M. (10 Steps)
Regulating wheel motor	2 HP
Regulating wheel tilt angle	+5° ~ -3°
Regulating wheel swivel angle	±5°
Upper slide feed handwheel	3.5mm/rev; 0.05mm/graduation
Upper slide micro-feed handwheel	0.1mm/rev; 0.001mm/graduation
Lower slide feed handwheel	9mm/rev; 0.05mm/graduation
Lower slid micro-feed handwheel	0.2mm/rev; 0.001mm/graduation
Feed adjusting handwheel	2mm/rev; 0.01mm/graduation
Hydraulic pump motor	1 HP
Coolant pump motor	1/4 HP
Machine dimension (L x W x H)	2300 x 2000 x 1650mm
New weight / Gross weight	2800 kg / 3100 kg

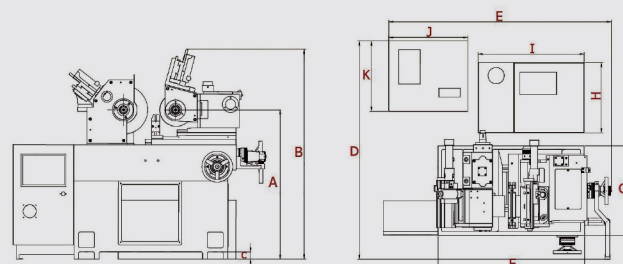
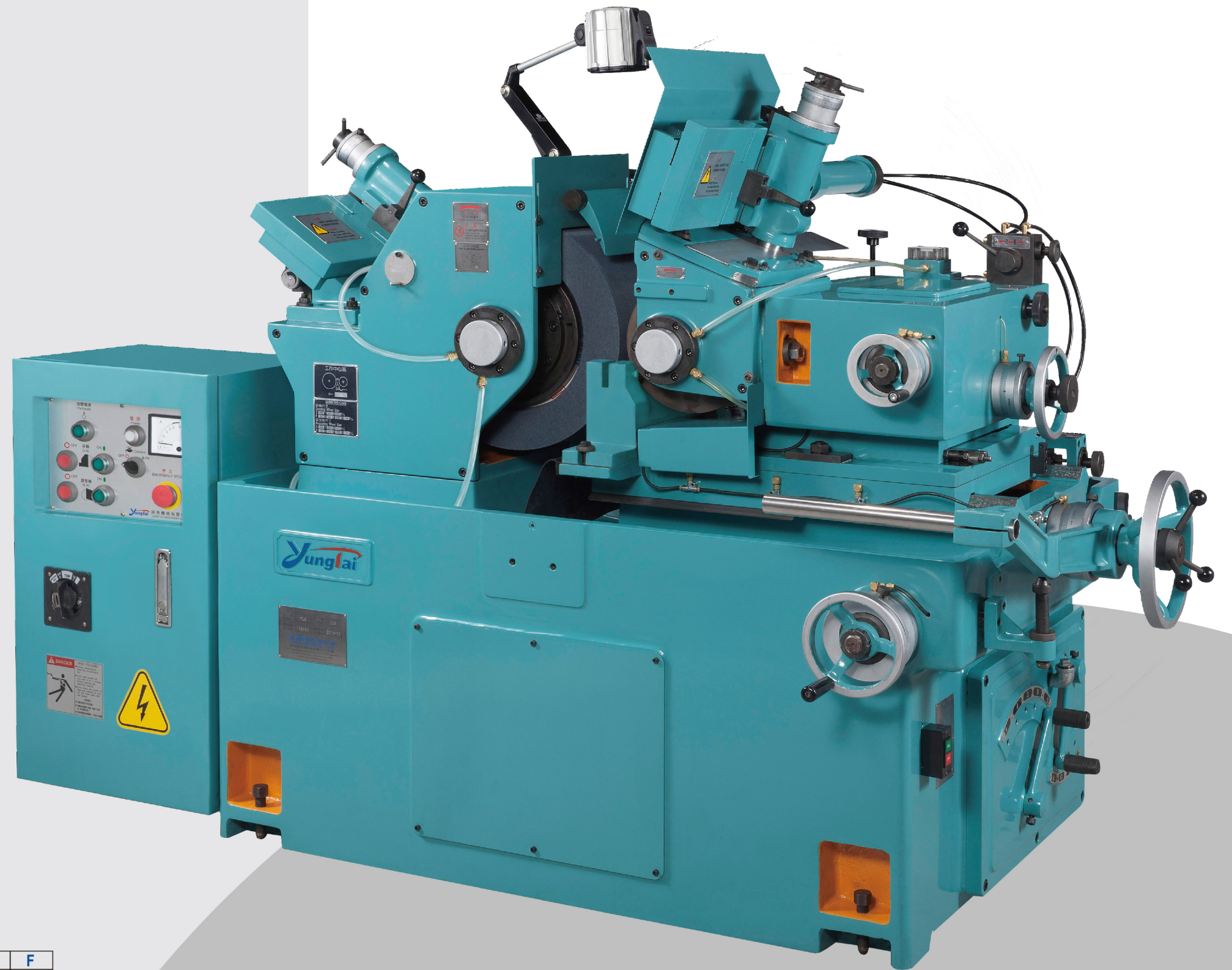

A	B	C	D	E	F
990	1650	45	2000	2300	1460
G	H	I	J	K	
920	750	1300	550	700	(mm)

※We reserve the right to change the design and specifications of our products without further notice.

Centerless Grinder

YTC-18A

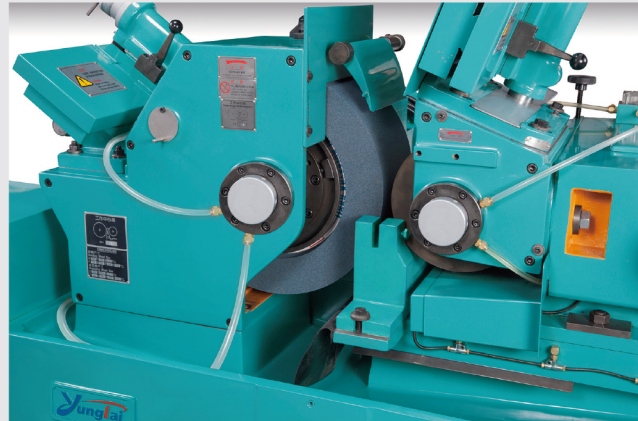

SPECIFICATION	
Model No.	YTC-18A
Standard grinding range (Dia.)	Ø2~Ø60mm
Capacity increases with special arrangement	Ø50~Ø150mm
Grinding wheel size (OD x Width x ID)	Ø455 x 255 x Ø228.6mm
Regulating wheel speed	1380 R.P.M.
Grinding wheel motor	15 HP
Regulating wheel size (OD x Width x ID)	Ø255 x 255 x Ø111.2mm
Regulating wheel speed	13~316 R.P.M. (10 Steps)
Regulating wheel motor	2 HP
Regulating wheel tilt angle	+5° ~ -3°
Regulating wheel swivel angle	±5°
Upper slide feed handwheel	3.5mm/rev; 0.05mm/graduation
Upper slide micro-feed handwheel	0.1mm/rev; 0.001mm/graduation
Lower slide feed handwheel	9mm/rev; 0.05mm/graduation
Lower slid micro-feed handwheel	0.2mm/rev; 0.001mm/graduation
Feed adjusting handwheel	2mm/rev; 0.01mm/graduation
Hydraulic pump motor	1 HP
Coolant pump motor	1/4 HP
Machine dimension (L x W x H)	2300 x 2000 x 1650mm
New weight / Gross weight	2900 kg / 3200 kg

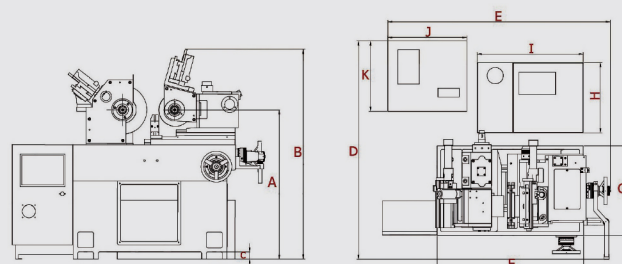

A	B	C	D	E	F
990	1650	45	2000	2300	1460
G	H	I	J	K	
920	750	1300	550	700	(mm)

※We reserve the right to change the design and specifications of our products without further notice.

Servo type Centerless Grinder

YTC-18S

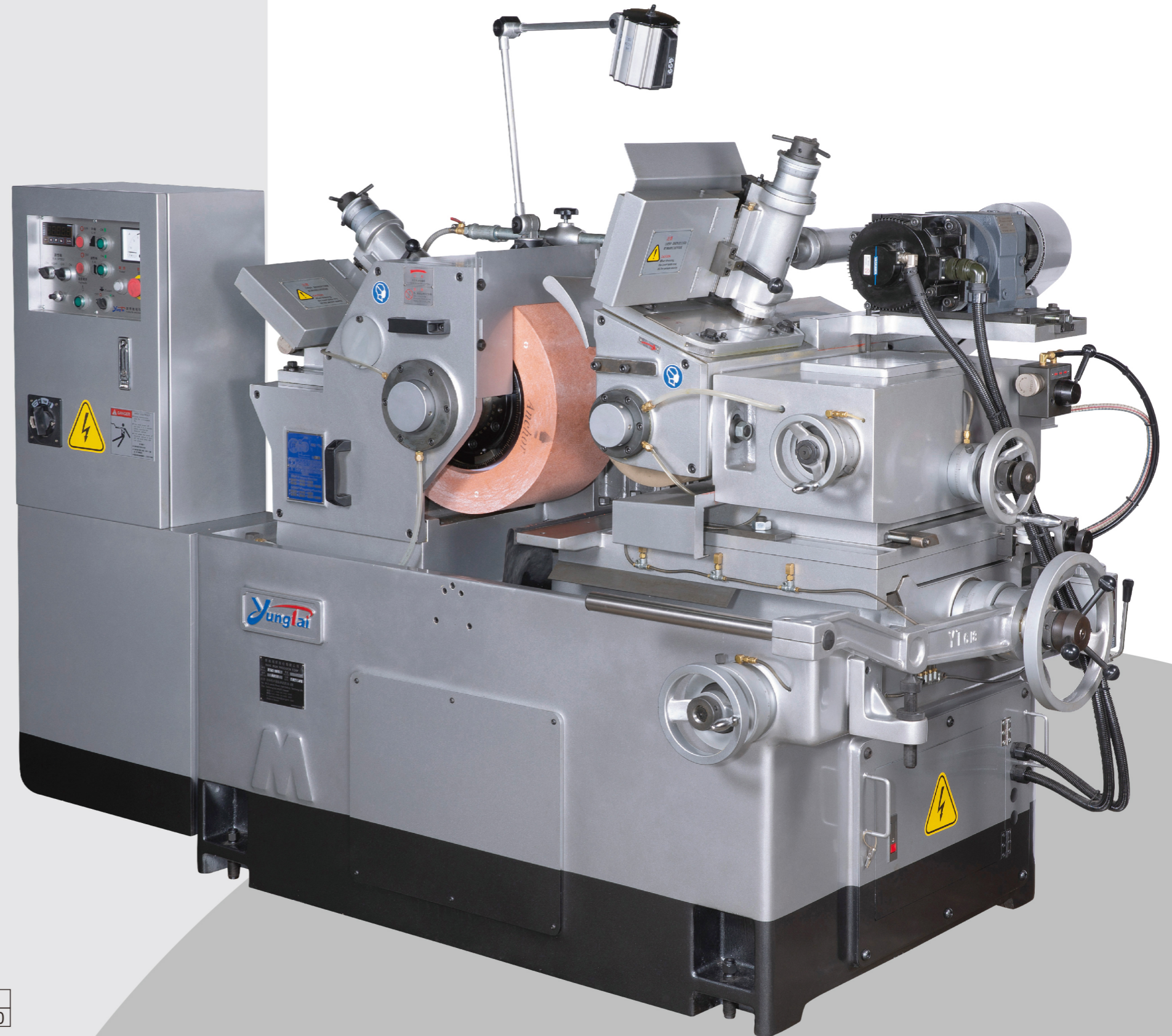
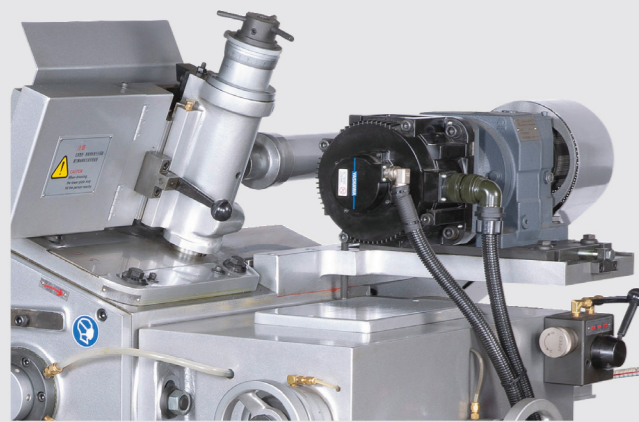

SPECIFICATION

Model No.	YTC-18S
Standard grinding range (Dia.)	Ø2~Ø60mm
Capacity increases with special arrangement	Ø50~Ø100mm
Grinding wheel size (OD x Width x ID)	Ø455 x 205 x Ø228.6mm
Regulating wheel speed	1380 R.P.M.
Grinding wheel motor	15 HP
Regulating wheel size (OD x Width x ID)	Ø255 x 205 x Ø111.2mm
Regulating wheel speed	10~250 R.P.M. (Stepless)
Regulating wheel motor	2.9 KW Servo Motor
Regulating wheel tilt angle	+5° ~ -3°
Regulating wheel swivel angle	±5°
Upper slide feed handwheel	3.5mm/rev; 0.05mm/graduation
Upper slide micro-feed handwheel	0.1mm/rev; 0.001mm/graduation
Lower slide feed handwheel	9mm/rev; 0.05mm/graduation
Lower slid micro-feed handwheel	0.2mm/rev; 0.001mm/graduation
Feed adjusting handwheel	2mm/rev; 0.01mm/graduation
Hydraulic pump motor	1 HP
Coolant pump motor	1/4 HP
Machine dimension (L x W x H)	2300 x 2000 x 1650mm
New weight / Gross weight	2800 kg / 3100 kg

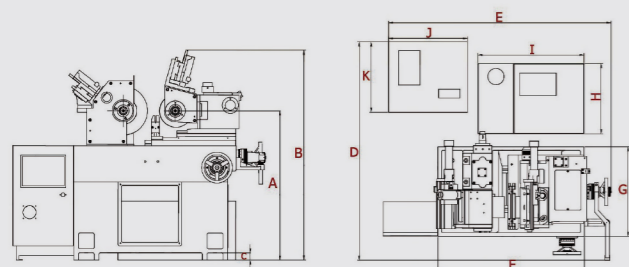

A	B	C	D	E	F
990	1650	45	2000	2300	1460

G	H	I	J	K
920	750	1300	550	700

(mm)

※We reserve the right to change the design and specifications of our products without further notice.

Servo type Centerless Grinder (NC 3-AXIS)

YTC-18AS-NC-III

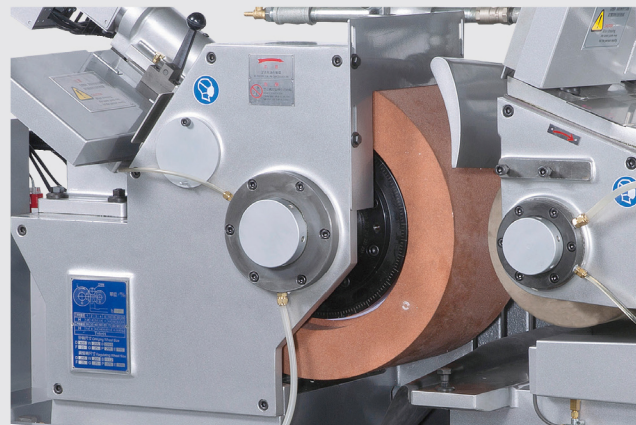

SPECIFICATION

Model No.	YTC-18AS-NC-III
Standard grinding range (Dia.)	Ø2~Ø60mm
Capacity increases with special arrangement	Ø50~Ø150mm
Grinding wheel size (OD x Width x ID)	Ø455 x 255 x Ø228.6mm
Regulating wheel speed	1380 R.P.M.
Grinding wheel motor	15 HP
Regulating wheel size (OD x Width x ID)	Ø255 x 255 x Ø111.2mm
Regulating wheel speed	10~250 R.P.M. (Stepless)
Regulating wheel motor	2.9 KW Servo Motor
Regulating wheel tilt angle	+5° ~ -3°
Regulating wheel swivel angle	±5°
Upper slide feed handwheel	3.5mm/rev; 0.05mm/graduation
Upper slide micro-feed handwheel	0.1mm/rev; 0.001mm/graduation
Lower slide feed handwheel	9mm/rev; 0.05mm/graduation
Lower slid micro-feed handwheel	0.2mm/rev; 0.001mm/graduation
Feed adjusting handwheel	2mm/rev; 0.01mm/graduation
Hydraulic pump motor	1 HP
Coolant pump motor	1/4 HP
Machine dimension (L x W x H)	2300 x 2000 x 1650mm
New weight / Gross weight	3000 kg / 3300 kg

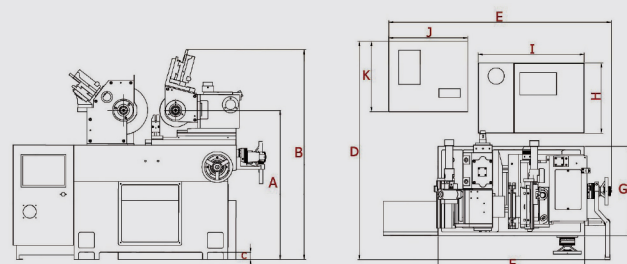

A	B	C	D	E	F
990	1650	45	2000	2300	1460
G	H	I	J	K	
920	750	1300	550	700	(mm)

NC~CNC schematic diagram

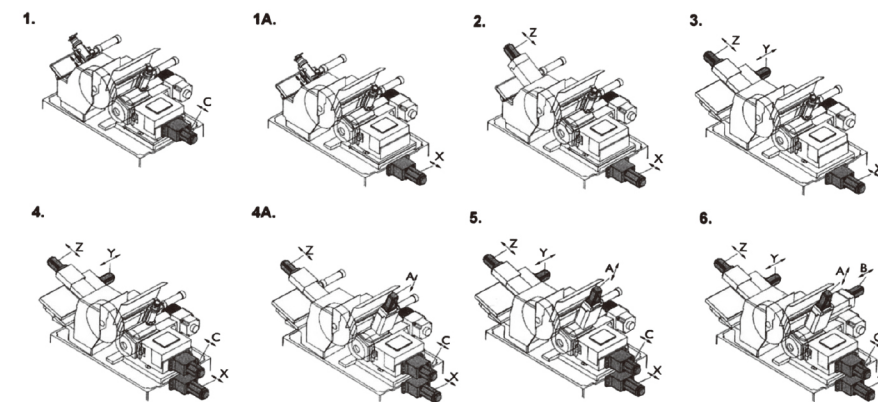

※We reserve the right to change the design and specifications of our products without further notice.

Standard Devices

www.yungtai.com



1 Grinding wheel and flange



2 Regulating wheel and flange

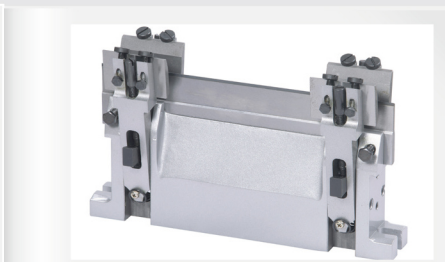

3 Thrufeed work rest and carbide blade

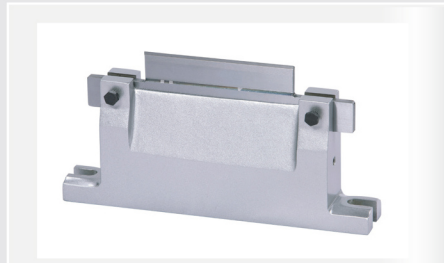

4 Infeed work rest and carbide blade



5 Diamond tools x 2



6 Thrufeed safety pressing device

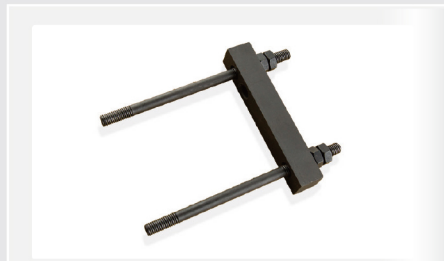

7 Wheel flange extractor



8 Thrufeed work rest



9 Cutting fluid tank & pump



10 Front / Rear waterproof cover



11 Hydraulic tank and pump

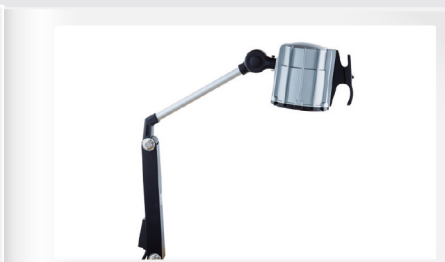

12 Work lamp

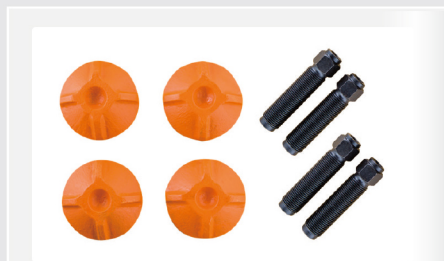

13 Leveling screw and plate

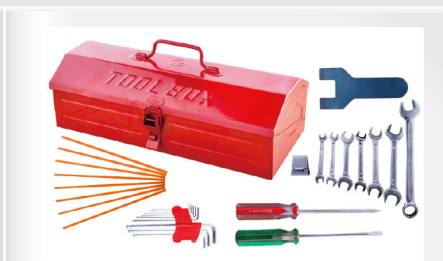

14 Tools and tool box

Optional Devices



1 Magnetic filter



2 Paper filter



3 Vibratory feeder



4 Hydrocyclone coolant separator



5 Auto. Feeder device for thrufeed grinding

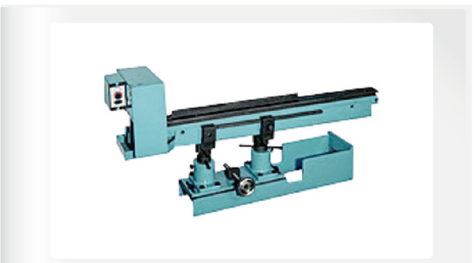

6 Auto. Collecting device for thrufeed grinding



7 Profile grinding device



8 Supporter for long bar grinding

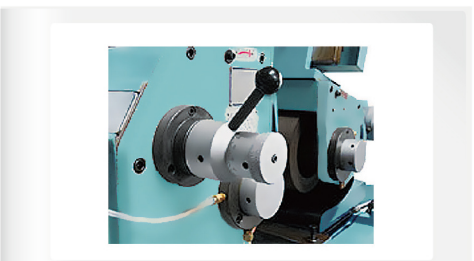

9 End face grinding device



10 Balancing stand and arbor



11 Auto. Loading & Unloading attachment for infeed grinding

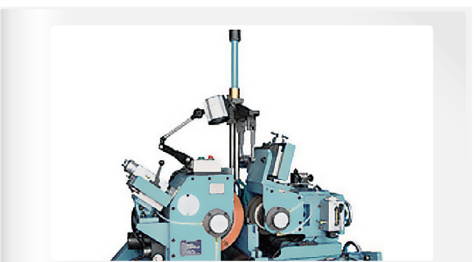

12 Manual feeder for infeed grinding



13 Manual rejector for infeed grinding